

407

C

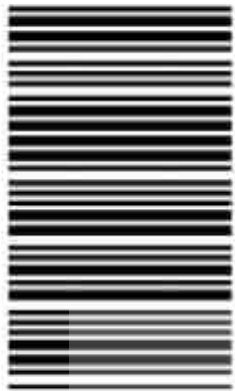

407C

نام :
نام خانوادگی :
محل امضاء :

دفترچه شماره ۱
عصر پنجشنبه
۹۳/۱۱/۱۶



جمهوری اسلامی ایران
وزارت علوم، تحقیقات و فناوری
سازمان سنجش آموزش کشور

اگر دانشگاه اصلاح شود مملکت اصلاح می شود.
امام خمینی (ره)

آزمون ورودی دوره‌های کارشناسی ارشد ناپیوسته داخل - سال ۱۳۹۴

مجموعه مهندسی برق - کد ۱۲۵۱

مدت پاسخگویی: ۱۰۵ دقیقه

تعداد سؤال: ۵۴

عنوان مواد امتحانی، تعداد و شماره سؤالات

ردیف	مواد امتحانی	تعداد سؤال	از شماره	تا شماره
۱	زبان عمومی و تخصصی	۳۰	۱	۳۰
۲	ریاضیات (سادات ديفرانسیل، ریاضیات مهندسی، آمار و احتمالات)	۱۲	۳۱	۴۲
۳	مدارهای الکتریکی ۱ و ۲	۱۲	۴۳	۵۴

این آزمون نمره منفی دارد.
استفاده از ماشین حساب مجاز نیست.

بهمن ماه - سال ۱۳۹۳

حق چاپ، تکثیر و انتشار سؤالات به هر روش (الکترونیکی و ...) پس از برگزاری آزمون، برای تمامی اشخاص حقیقی و حقوقی تنها با مجوز این سازمان مجاز می باشد و با متخلفین برابر مقررات رفتار می شود.

PART A: Vocabulary

Directions: Choose the word or phrase (1), (2), (3), or (4) that best completes each sentence. Then mark your answer sheet.

- 1- Jane was terribly bored, but she ----- interest so as not to hurt her friend's feelings.
1) admitted 2) validated 3) endeavored 4) feigned
- 2- Having a ----- knowledge of economics, I did not understand anything out of the speaker's speech.
1) rudimentary 2) superfluous 3) hazardous 4) clandestine
- 3- In the hands of inexperienced drivers, high-powered cars are actually ----- weapons.
1) inflexible 2) lethal 3) regretful 4) spontaneous
- 4- The many ----- in the text for sure detract from its real value.
1) safeguards 2) variables 3) digressions 4) consistencies
- 5- The human brain is well known to differ considerably from the chimpanzee brain in ----- of size, organization and complexity, among other traits.
1) light 2) regards 3) terms 4) aspect
- 6- Irrigation is essential to most high-yield farming, but many aquifers that supply irrigated crops are being drawn down faster than rain can ----- them.
1) deplete 2) overcome 3) vanish 4) recharge
- 7- It is a pity that he ----- between the two neighboring countries is well rooted and hard to remove.
1) misanthropy 2) antipathy 3) urgency 4) vagueness
- 8- Hair that's thick and ----- needs regular trimming.
1) luxuriant 2) arbitrary 3) excessive 4) fragmented
- 9- Their lack of qualifications ----- them to a lifetime of boring, usually poorly-paid, work.
1) devoted 2) conveyed 3) condemned 4) captivated
- 10- The ----- of differences among cultures clearly shows that mental health professionals are ill advised to apply their classifications of personality disorders to people from other cultures.
1) dispersal 2) disarray 3) ignorance 4) multitude

PART B: Cloze Passage

Directions: Read the following passage and decide which choice (1), (2), (3), or (4) best fits each space. Then mark your answer sheet.

The Olympic stadium was silent. The spectators held their collective breath. The 100-meter finalists, crouched against their starting blocks, (11) ----- their backs as the starter raised his pistol and announced, "Set... !" Each powerful sprinter, poised to explode when the gun went off, was keenly aware of what hung in the balance. They had trained (12) ----- every day for years to prepare their bodies for this one race.

But had they disciplined their minds? The runner who would break the tape would need (13) ----- strong muscles, heart and lungs. He would need concentration, control, confidence—and an unerring eye (14) ----- . At this tense moment, one mistimed twitch could cause a false start and cost him the race. But if he eased off in any way, his first steps would lag behind (15) -----, guaranteeing a loss. "Bang!"

- 11- 1) they raised 2) raising 3) raised 4) by raising
- 12- 1) and exhausted 2) to exhaustion
3) for being exhaustive 4) exhausting
- 13- 1) as well as 2) not only
3) more than 4) by far
- 14- 1) to the finishing line 2) to finish the line
3) for the line to finish 4) on the finish line

- 15-1) those of his competitors
 2) his competitors
 3) what did his competitors
 4) the one in his competitors

PART C: Reading Comprehension

Directions: Read the following three passages and answer the questions by choosing the best choice (1), (2), (3), or (4) and then mark the correct choice on your answer sheet.

PASSAGE 1:

Remote sensing refers to obtaining information about objects or areas using electromagnetic radiation without being in direct contact with them. In remote sensing various types of tools and devices are utilized to make electromagnetic radiation outside this range visible to the human eye.

Since the first launch of an earth observation satellite, remote sensing is increasingly used to acquire information about environmental processes such as agricultural crops, land cover, vegetation dynamics, water quality, urban growth, seabed topography, etc. Remote sensing helps us to increase our understanding of the ecological system of the earth. Remote sensing helps us to measure the size of the ozone hole in the atmosphere, to notice the differences of atmospheric ozone concentrations between the southern and northern hemisphere. Remote sensing is playing a key role in our efforts to understand the complex dynamics of ocean circulation: the Northern Atlantic Oscillation and to assess their effects on global and regional climates and extreme events. Long-term remote sensing observations of the Sahel region made us at least partly understand the complex cyclic pattern radar that were developed at that time: SLAR: side-looking airborne radar and SAR: Synthetic Aperture Radar. Either development aimed at the acquisition of images at the highest possible resolution. Crucial to the SAR development was the ability to finely resolve the Doppler frequencies using a frequency analysis algorithm on the returning radar signal by the US Air Force research centre.

- 16- **The word "Urban" in the second paragraph means:**
- 1) Country
 - 2) Rural area
 - 3) The area with higher population density
 - 4) The area surrounding cities
- 17- **"Cyclic patterns" can be replaced by:**
- 1) Periodic schemes
 - 2) Plainness diagrams
 - 3) Motifs which are complex to understand
 - 4) Patterns which should be studied more extensively
- 18- **According to the Passage, the critical point in designing SAR is:**
- 1) to be used in remote sensing
 - 2) to develop an aperture for the radar
 - 3) to combat the effect of Doppler frequency
 - 4) to use the Doppler frequency to design a frequency analyzer

- 19- **According to the Passage, what is the purpose of remote sensing?**
- 1) A method restricted to use radar systems for sensing
 - 2) Making electromagnetic radiations visible to human eyes
 - 3) Analysis of dynamics of ozone concentration in the atmosphere using radars.
 - 4) The use of aerial sensors to detect and classify objects or their alternations which are mostly on Earth.
- 20- **What does the sentence "Either development aimed at the acquisition of images at the highest possible resolution." mean?**
- 1) Radar systems are required to acquire the picture of a target.
 - 2) The goal of both SAR and SLAR is to forfeit high resolution pictures.
 - 3) The high resolution pictures have an important role in remote sensing.
 - 4) The high resolution image of every developed radar system might be captured as a target.

PASSAGE 2:

Renewable energy is generally defined as energy that comes from resources which are naturally replenished on a human timescale such as sunlight, wind, rain, tides, waves and geothermal heat. Renewable energy replaces conventional fuels in four distinct areas: electricity generation, hot water/space heating, motor fuels, and rural (off-grid) energy services. Renewable energy resources exist over wide geographical areas, in contrast to other energy sources, which are concentrated in a limited number of countries. Rapid deployment of renewable energy and energy efficiency is resulting in significant energy security, climate change mitigation, and economic benefits. In international public opinion surveys, there is strong support for promoting renewable sources such as solar power and wind power. At the national level, at least 30 nations around the world already have renewable energy contributing more than 20 percent of energy supply. National renewable energy markets are projected to continue to grow strongly in the coming decade and beyond.

- 21- **The underlined word in the passage can be replaced by:**
- 1) Studies
 - 2) storage
 - 3) Supplies
 - 4) Standards
- 22- **Which one of the following cases is NOT a reason for renewable energy development?**
- 1) It can be replenished.
 - 2) It can lead to undesirable climate change.
 - 3) It is more reasonable financially.
 - 4) It is distributed more evenly throughout the world compared with other types of recourses.
- 23- **The word "conventional" in the third line of the passage can be replaced by?**
- 1) electrical
 - 2) modern
 - 3) solar
 - 4) traditional
- 24- **What is the distinct feature and characteristic of renewable energies?**
- 1) They are not depleted over time.
 - 2) They should be produced synthetically.
 - 3) They cannot be consumed very quickly.
 - 4) They are available only in certain circumstances.

PASSAGE 3:

Vacuum-channel transistor is the result of a marriage between traditional vacuum-tube technology and modern semiconductor-fabrication techniques. This curious hybrid combines the best aspects of vacuum tubes and transistors and can be made as small and as cheap as any solidstate device. Indeed, making them small is what eliminates the well-known drawbacks of vacuum tubes.

In a vacuum tube, an electric filament is used to heat the cathode sufficiently for it to emit electrons. This is why vacuum tubes need time to warm up and consume so much power. It is also the reason they frequently burn out. However, vacuum-channel transistors do not need a filament or hot cathode. If the device is made small enough, the electric field across it is sufficient to draw electrons from the source by a process known as field emission. Eliminating the power-sapping heating element reduces the area each device takes upon a chip and makes this new kind of transistor energy efficient. Another weak point of tubes is that they must maintain a high vacuum to avoid collisions between electrons and gas molecules. Under such low pressure, the electric field causes positive ions generated from the residual gas in a tube to accelerate and bombard the cathode, creating sharp, nanometer-scale protrusions, which degrade and, ultimately, destroy it.

These long-standing problems of vacuum electronics are not insurmountable. If the distance between cathode and anode were less than the average distance an electron travels before hitting a gas molecule, a distance known as the mean free path, and the working voltage is low enough, the device can operate just fine at atmospheric pressure. That is, you do not, in fact, need to maintain any sort of vacuum at all for what is nominally a miniaturized piece of vacuum electronics.

- 25- What is the **main idea** of the above passage?
- 1) main problems of vacuum electronics.
 - 2) solutions for drawbacks of vacuum tubes.
 - 3) vacuum-tube technology and its applications.
 - 4) combination of an extinct device with a new technology.
- 26- Which of the following is **NOT stated** in the passage as a vacuum tube problem?
- 1) low longevity.
 - 2) long setup time.
 - 3) high fabrication cost.
 - 4) low energy efficiency.
- 27- In a vacuum-channel transistor, electrons are drawn from the source by a process called -----.
- 1) field emission.
 - 2) power-sapping.
 - 3) mean free path.
 - 4) nanometer-scale protrusions.
- 28- The pronoun "**it**" in the second paragraph refers to -----.
- 1) tube
 - 2) cathode
 - 3) residual gas
 - 4) electric field
- 29- The word "**insurmountable**" in the last paragraph is closest in meaning to -----.
- 1) unsolvable
 - 2) inaccessible
 - 3) invaluable
 - 4) unpredictable
- 30- The word "**drawback**" in the first paragraph cannot be replaced by -----.
- 1) benefits
 - 2) problems
 - 3) impairments
 - 4) adverse aspects

ریاضیات (معادلات دیفرانسیل، ریاضیات مهندسی، آمار و احتمالات):

۳۱- جعبه I شامل ۵ مهره سفید و ۷ مهره سیاه است. جعبه II شامل ۲ مهره سفید و ۲ مهره سیاه است. دو مهره به تصادف و بدون جایگذاری از جعبه I انتخاب و بدون مشاهده رنگ مهره‌ها در جعبه II قرار می‌دهیم. سپس دو مهره از جعبه II به تصادف و بدون جایگذاری انتخاب می‌کنیم. احتمال پیشامد دو مهره سفید از جعبه II کدام است؟

- (۱) $\frac{13}{165}$
 (۲) $\frac{13}{156}$
 (۳) $\frac{31}{165}$
 (۴) $\frac{31}{156}$

۳۲- تابع چگالی احتمال یک قطعه الکترونیکی بر حسب ساعت به صورت زیر است:

$$f(x) = \begin{cases} \frac{C}{x^2} & x > 10 \\ 0 & x \leq 10 \end{cases}$$

احتمال آنکه از ۶ قطعه الکترونیکی حداکثر ۲ قطعه برای حداقل ۱۵ ساعت کار کنند (با فرض مستقل بودن پیشامد خراب شدن قطعات)، کدام است؟

- (۱) $\frac{60}{3^6}$
 (۲) $\frac{60C}{3^6}$
 (۳) $\frac{73}{3^6}$
 (۴) $\frac{73C}{3^6}$

۳۳- اگر رنسکین $w(f, g)$ مربوط به توابع f و g برابر $3e^{4t}$ و $f(t) = e^{2t}$ باشد، در این صورت کلیه توابع g ممکن کدام است؟

- (۱) $(4t+c)e^{2t}$
 (۲) $(3t+c)e^{2t}$
 (۳) $(2t+c)e^{2t}$
 (۴) $2t+c$

۳۴- اگر $y_1(x) = e^x$ یک جواب معادله دیفرانسیل $xy'' - (x+n)y' + ny = 0$ و $n \in \mathbb{N}$ باشد، جواب مستقل دیگر کدام گزینه می‌تواند باشد؟

$$\sum_{k=0}^n \frac{1}{k!} x^k \quad (1)$$

$$\sum_{k=0}^{n-1} \frac{1}{k!} x^k \quad (2)$$

$$\sum_{k=1}^n \frac{1}{k!} x^k \quad (3)$$

$$\sum_{k=1}^{n+1} \frac{1}{k!} x^k \quad (4)$$

۳۵- جواب مسأله مقدار اولیه $(x+1)^2 y'' + (x+1)y' + 4y = 0$ ، $y(0) = 1$ ، $y'(0) = 2$ ، کدام است؟

$$(x+1)^2 \quad (1)$$

$$\cos(\ln(x+1)^2) + \sin(\ln(x+1)^2) \quad (2)$$

$$\cos(\ln(x+1)) + 2\sin(\ln(x+1)) \quad (3)$$

$$\cos^2(\ln(x+1)^2) + \sin^2(\ln(x+1)^2) \quad (4)$$

۳۶- معادله دیفرانسیل $2x^2 y'' - xy' + (1+x)y = 0$ ، $x > 0$ ، داده شده است. معادله شاخص سری فروبنیوس،

و رابطه بازگشتی بین ضرایب آن، a_{n-1} ، a_n ، کدام است؟ ($n \geq 1$)

$$a_n = \frac{-a_{n-1}}{n(2n-1)}, a_n = \frac{-a_{n-1}}{n(2n+1)}, 2r^2 - 4r + 1 = 0 \quad (1)$$

$$a_n = \frac{-a_{n-1}}{(2n-1)n}, a_n = \frac{-a_{n-1}}{(2n+1)(n+1)}, 2r^2 - 2r + 1 = 0 \quad (2)$$

$$a_n = \frac{-a_{n-1}}{(2n-1)(n+1)}, a_n = \frac{-a_{n-1}}{(2n+1)n}, 2r^2 - 2r + 1 = 0 \quad (3)$$

$$a_n = \frac{-a_{n-1}}{n(2n-1)}, a_n = \frac{-a_{n-1}}{(2n+1)n}, 2r^2 - 2r + 1 = 0 \quad (4)$$

۳۷- اگر $f(x) = \int_0^{+\infty} A(\omega) \cos(\omega x) d\omega$ ، $g(x) = \int_0^{+\infty} \omega \frac{dA(\omega)}{d\omega} \cos(\omega x) d\omega$ ، در این صورت $g(x)$

کدام است؟

$$-f(x) - xf'(x) \quad (1)$$

$$f(x) - xf'(x) \quad (2)$$

$$f(x) - xf''(x) \quad (3)$$

$$f(x) + xf''(x) \quad (4)$$

۳۸- در مسأله مقدار اولیه مرزی

$$\begin{cases} u_{tt} - u_{xx} = \sin^2(\pi x), & 0 < x < 1, t > 0 \\ u(0, t) = 0 = u(1, t), & t > 0 \quad \text{شرایط مرزی} \\ u(x, 0) = 0, \quad u_t(x, 0) = 0 & \text{شرایط اولیه} \end{cases}$$

جوابی مستقل از زمان از معادله دیفرانسیل که در شرایط مرزی نیز صدق کند، کدام است؟

$$\frac{2}{3\pi^2} \sin(\pi x) + \frac{1}{9\pi^2} \sin^2(\pi x) \quad (1)$$

$$\frac{2}{\pi^2} \sin(\pi x) + \frac{1}{3\pi^2} \sin^2(\pi x) \quad (2)$$

$$\frac{2}{3\pi^2} \sin(\pi x) + \frac{1}{9\pi^2} \sin^2(\pi x) \quad (3)$$

$$x(1-x) + \frac{2}{3\pi^2} \sin(\pi x) + \frac{1}{9\pi^2} \sin^2(\pi x) \quad (4)$$

۳۹- جواب معادله با مشتقات جزئی زیر، با شرایط اولیه مرزی داده شده، کدام است؟

$$\begin{cases} u_{xx} = tu_t, & 0 < x < \pi, t > 1 \\ u(0, t) = u(\pi, t) = 0, & t \geq 1 \\ u(x, 1) = 1, & 0 < x < \pi \end{cases}$$

$$\sum_{k=0}^{\infty} \frac{4}{k\pi} t^{-k^2} \sin kx \quad (1)$$

$$\sum_{k=0}^{\infty} \frac{4}{k\pi} e^{-k^2 t} \sin kx \quad (2)$$

$$\sum_{k=0}^{\infty} \frac{4}{(2k+1)\pi} e^{-(2k+1)^2 t} \sin(2k+1)x \quad (3)$$

$$\sum_{k=0}^{\infty} \frac{4}{(2k+1)\pi} t^{-(2k+1)^2} \sin(2k+1)x \quad (4)$$

۴۰- می دانیم پاسخ معادله حرارت به صورت:

$$\frac{\partial u}{\partial t} = c^2 \frac{\partial^2 u}{\partial x^2}, \quad 0 < x < l, \quad t > 0$$

با شرایط مرزی $\frac{\partial u(0, t)}{\partial x} = 0$, $\frac{\partial u(l, t)}{\partial x} + hu(l, t) = 0$ به شکل زیر است:

$$u(x, t) = \sum_{n=0}^{\infty} A_n e^{-k_n^2 c^2 t} \cos(k_n x)$$

در این صورت k_n ها در کدام معادله زیر صدق می کنند؟

$$k_n \tan k_n l = -h \quad (1)$$

$$k_n \cot k_n l = -h \quad (2)$$

$$k_n \cot k_n l = h \quad (3)$$

$$k_n \tan k_n l = h \quad (4)$$

۴۱- حاصل $\oint_C \frac{z^2}{z-i} \log\left(\frac{z+1}{z-1}\right) dz$ در صورتی که C دایره $|z-i| = \frac{1}{2}$ باشد که در جهت مثلثاتی پیموده شده است، برابر کدام گزینه است؟

$$-i\pi^2 \quad (1)$$

$$-\pi^2 \quad (2)$$

$$i\pi^2 \quad (3)$$

$$\pi^2 \quad (4)$$

۴۲- مقدار انتگرال $\oint_C \frac{dz}{2 - \sin z}$ بر روی دایره C به مرکز مبدأ و به شعاع $\frac{3}{2}$ ، کدام است؟ (C در جهت مثلثاتی پیموده شده)

(1)

$$2\pi i \left[\frac{\pi}{2} + i \ln(2 + \sqrt{3}) \right] \quad (2)$$

$$2\pi i \left[-\frac{\pi}{2} + i \ln(2 + \sqrt{3}) \right] \quad (3)$$

$$2\pi i \left[\frac{\pi}{2} - i \ln(2 + \sqrt{3}) \right] \quad (4)$$

مدارهای الکتریکی (۱ و ۲):

۴۳- در مدار شکل زیر، اگر بین A و B را اتصال کوتاه کنیم جریان 2^A از A به B می‌گذرد. و اگر بین B و C را اتصال کوتاه کنیم جریان 3^A از B به C می‌گذرد. شبکه معادل تونن دیده شده (V_{th}, R_{th}) از سرهای A و B به ترتیب از راست به چپ چند اهم و ولت است؟

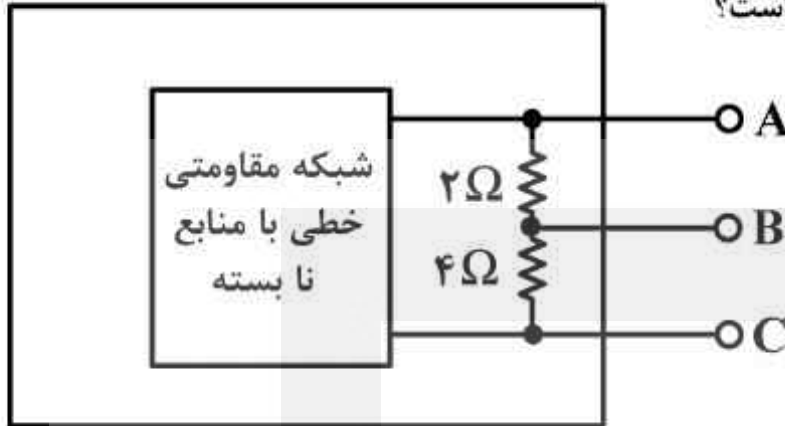

- (۱) $3, \frac{3}{2}$
- (۲) $12, 2$
- (۳) $2, 2$
- (۴) $4, 2$

۴۴- در مدار شکل زیر، توان مصرفی مقاومت غیر خطی با مشخصه $V_R = \frac{3}{2} i_R^2$ چند وات است؟

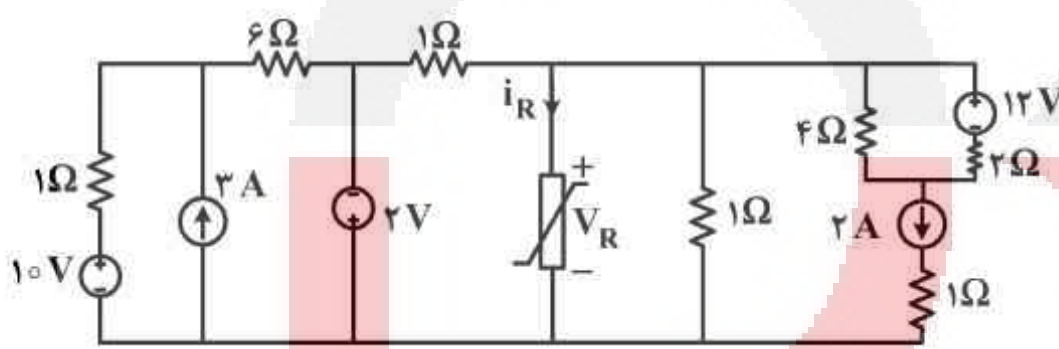

- (۱) $\frac{1}{3}$
- (۲) $\frac{2}{3}$
- (۳) $\frac{4}{3}$
- (۴) 2

۴۵- در مدار شکل زیر، خازن $C_1 = 1\mu F$ و بی‌بار است، خازن $C_2 = 2\mu F$ و به میزان ۲۵ میکرو ژول انرژی ذخیره شده با پلاریته داده شده دارد. با ورودی منبع ولتاژ $V_S(t)$ شکل زیر، کدام گزینه در مورد بازه زمانی هدایت دیود ایده‌آل D بر حسب میلی ثانیه صحیح است؟

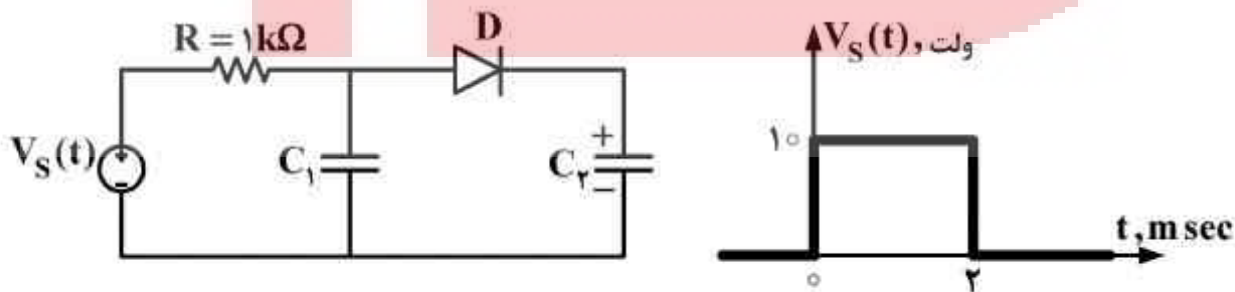

- (۱) $\ln \frac{3}{2} \leq t \leq 2$
- (۲) $\ln 2 \leq t \leq 2$
- (۳) $\ln \frac{3}{2} \leq t \leq 2 \ln 2$
- (۴) $\ln 2 \leq t \leq 2 \ln 2$

۴۶- مدار شکل زیر، به ازای چه مقدار مقاومت R (بر حسب اهم) نوسان می‌کند؟

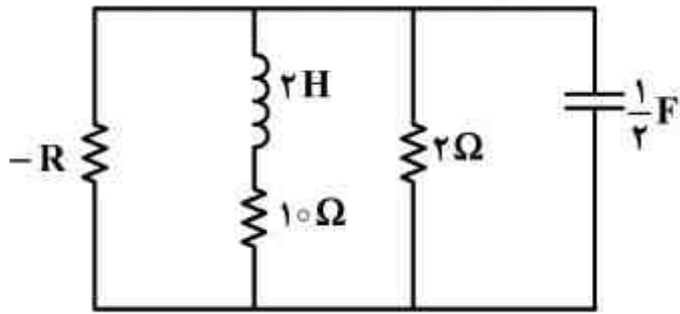

(۱) $\frac{1}{3}$

(۲) $\frac{10}{6}$

(۳) ۳

(۴) به ازای هیچ مقدار R نوسان نمی‌کند.

۴۷- مدار شکل زیر، از هر دو طرف به سمت بی‌نهایت می‌رود. با شرایط اولیه صفر، معادله ولتاژ دو سر منبع

جریان ضربه برای $t > 0$ برابر کدام است؟

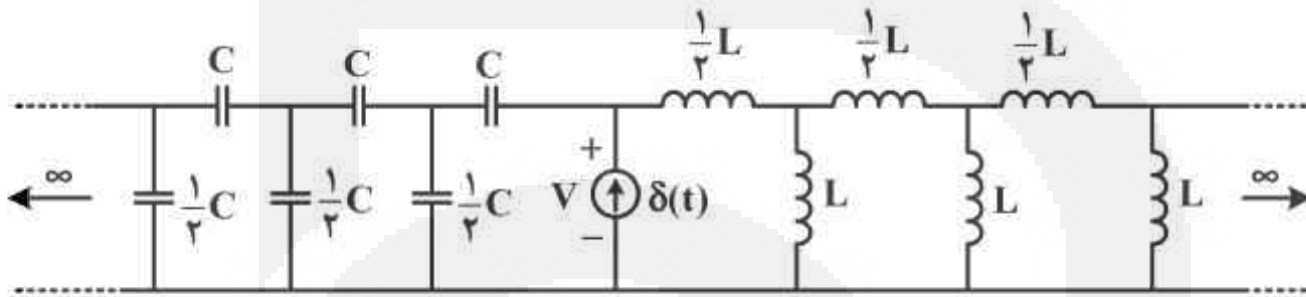

(۱) $\frac{1}{C} \sin \frac{t}{\sqrt{LC}}$

(۲) $\frac{1}{C} \cos \frac{t}{\sqrt{LC}}$

(۳) $\frac{2}{C} \sin \sqrt{\frac{2}{LC}} t$

(۴) $\frac{2}{C} \cos \sqrt{\frac{2}{LC}} t$

۴۸- در شبکه شکل زیر، که در حالت دائمی قرار دارد، مقدار ظرفیت خازن C باید چند فاراد باشد تا حداکثر

توان متوسط به مقاومت R برسد؟

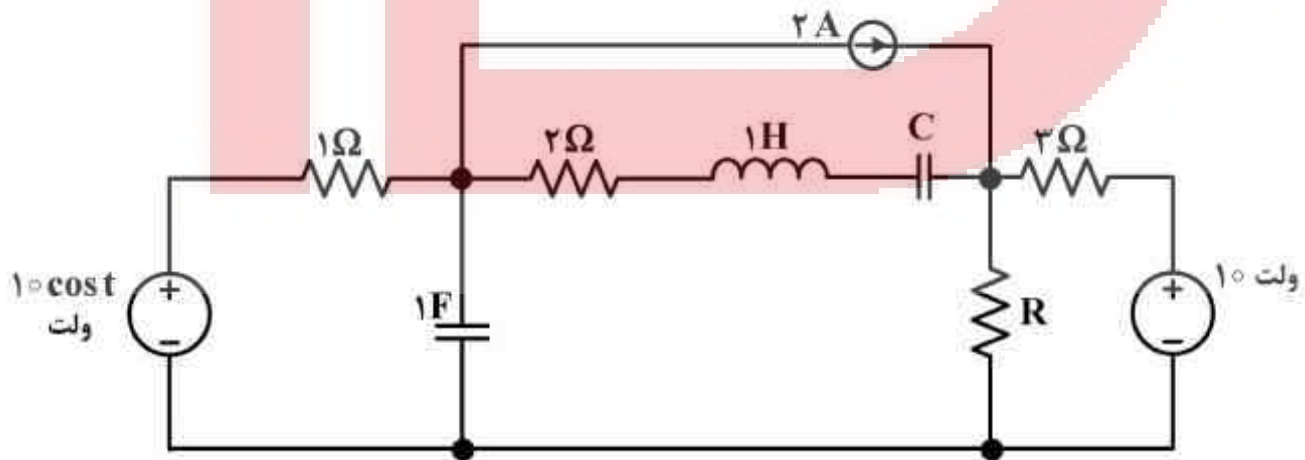

(۱) ۲

(۲) $\frac{2}{2}$

(۳) ۱

(۴) $\frac{1}{2}$

۴۹- در مدار شکل زیر، بردار حالت $x \triangleq \begin{bmatrix} i_L \\ v_C \end{bmatrix}$ می باشد. معادله مسیر حالت مدار کدام است؟

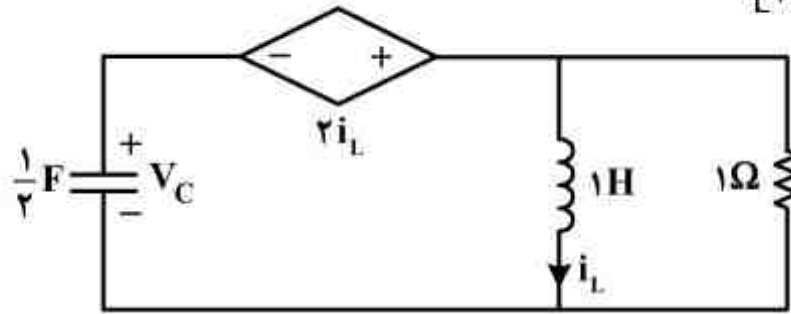

(۱) $2v_C + i_L - 2v_C i_L = 8$

(۲) $v_C + 4i_L + 4v_C i_L = 4$

(۳) $v_C + 6i_L + 4v_C i_L = 4$

(۴) $6v_C + i_L - 4v_C i_L = 4$

۵۰- مدار شکل زیر، به ازای شرایط اولیه غیر صفر، در چه فرکانسی (بر حسب هرتز) نوسان می کند؟

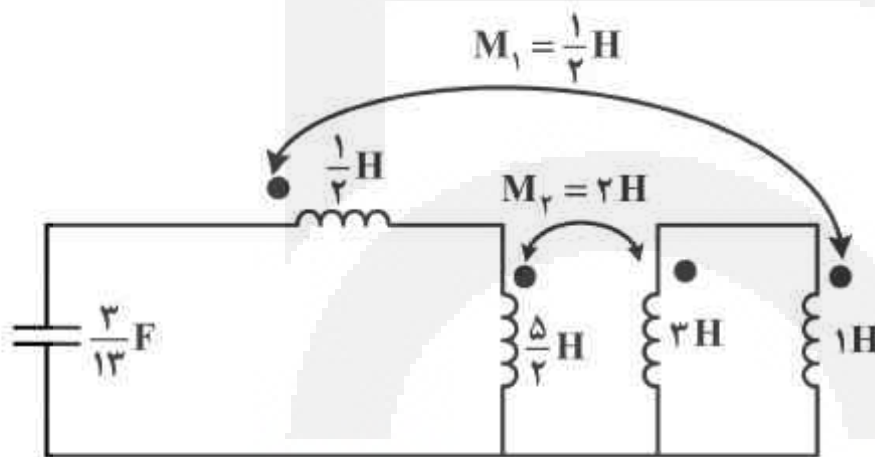

(۱) $\frac{3}{4\pi}$

(۲) $\frac{4}{2\pi}$

(۳) $\frac{3}{2\pi}$

(۴) $\frac{2}{3\pi}$

۵۱- در مدار شکل زیر، تابع انتقال شبکه‌ی $H(s) = \frac{V_o(s)}{I_s(s)}$ دارای چند قطب است و چه تعداد از آنها صفر است؟

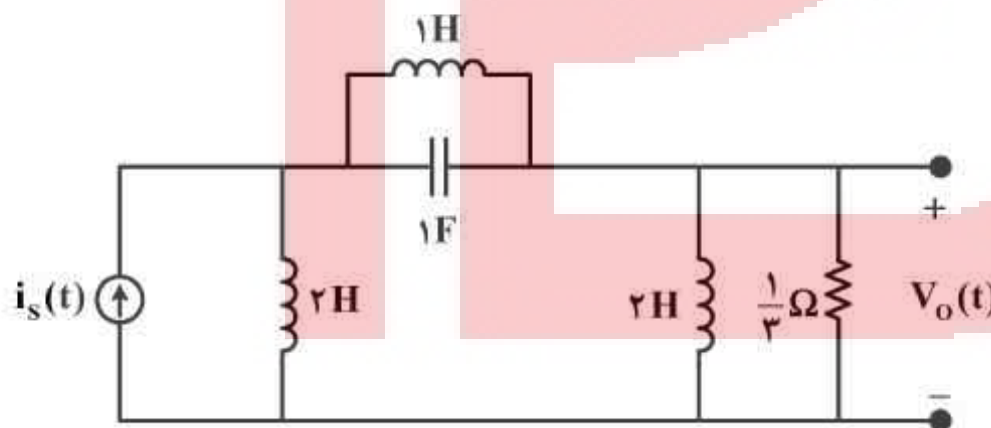

(۱) ۳، یکی

(۲) ۳، هیچکدام صفر نیستند.

(۳) ۴، یکی

(۴) ۴، هیچکدام صفر نیستند.

۵۲- پارامتر Y_{21} از ماتریس ادمیتانس و پارامتر A از ماتریس انتقال $T = \begin{bmatrix} A & B \\ C & D \end{bmatrix}$ برای دو دهنه خطی و

تغییرناپذیر با زمان N به صورت زیر داده شده‌اند:

$$Y_{21} = \frac{-s}{s+2}, A = \frac{1}{s}$$

پاسخ حالت صفر برای خروجی $V_o(t)$ در آزمایش شکل زیر، کدام است؟



- (۱) $e^{-2t}u(t)$
- (۲) $e^{-3t}u(t)$
- (۳) $(1-e^{-2t})u(t)$
- (۴) $(1-e^{-3t})u(t)$

۵۳- به ازای چه مقدار k مدار شکل زیر، فرکانس طبیعی صفر دارد؟

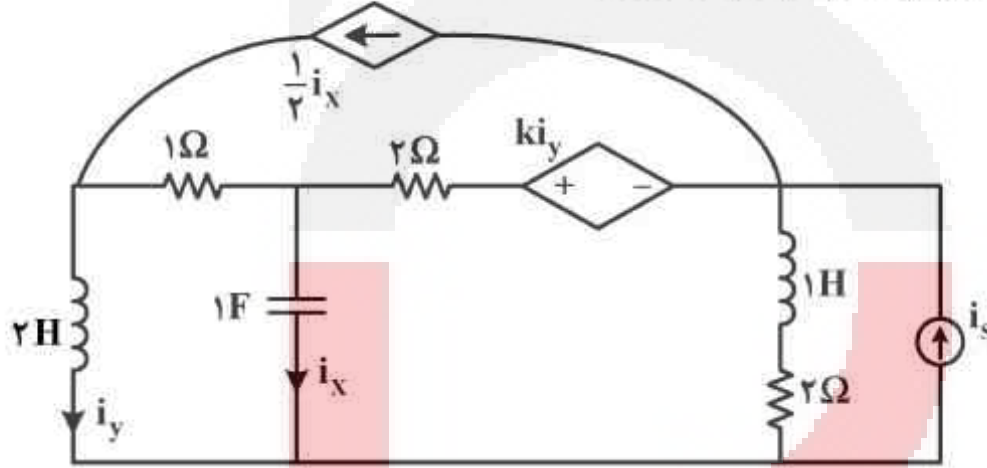

- (۱) $-\frac{1}{5}$
- (۲) $\frac{1}{5}$
- (۳) 5
- (۴) -5

۵۴- در شکل زیر، شبکه RLC یکسان در قطب دوم به واسطه یک ترانسفورماتور ایده‌آل به یکدیگر متصل شده‌اند. در صورتی که توان لحظه‌ای تحویل داده شده به سیم‌پیچ n_1 معادل $p(t) = \sin 2t$ باشد، جریان اتصال کوتاه $i_{sc}(t)$ کدام است؟



$$\frac{n_1}{n_2} = \frac{2}{3}$$

- (۱) $13 \cos t$
- (۲) $5 \sin t$
- (۳) $-5 \cos t$
- (۴) $-13 \cos t$

